

# HEAVY DUTY ECONOMY CYLINDER CART WITH FIREPROOF INSERT - CYL-EH-FP-FF

\*\*\*ANY ADDITIONS, DELETIONS, OR OMISSIONS MUST BE CORRECTED ON THIS DRAWING AS THIS DRAWING WILL BE CONSIDERED ALL INCLUSIVE\*\*\*

APPROX WEIGHT: 191.94 lbs.  
DOES NOT INCLUDE WEIGHT OF POWER OR PACKAGING!!!

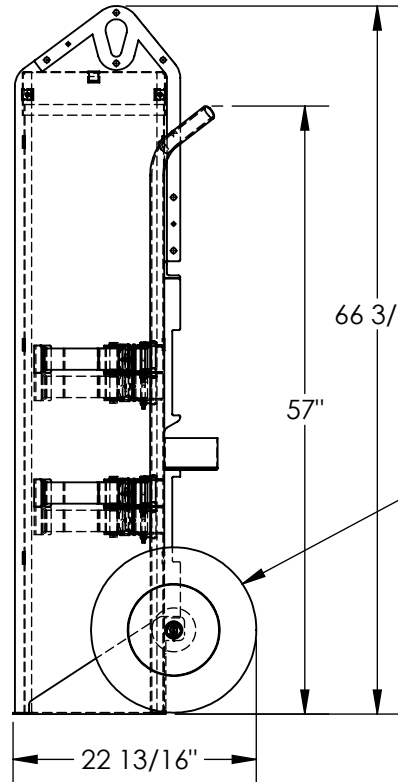
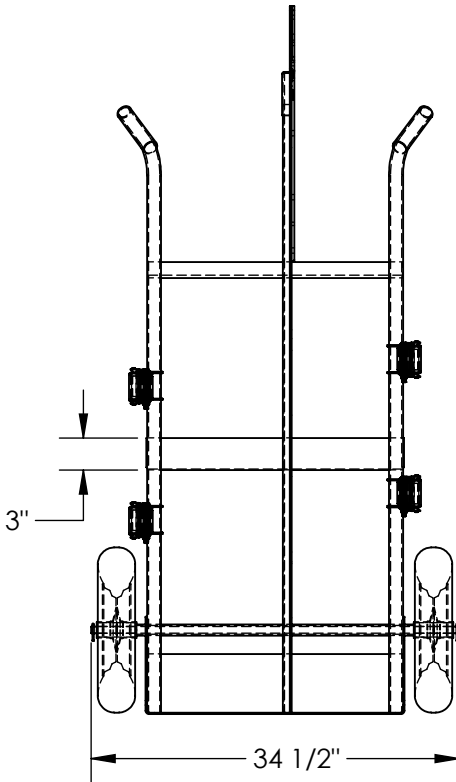
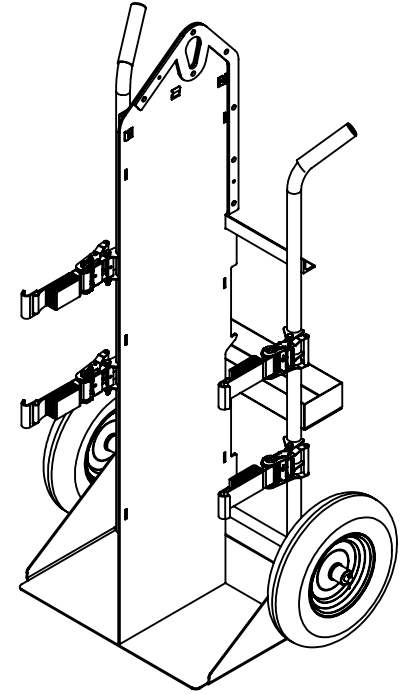
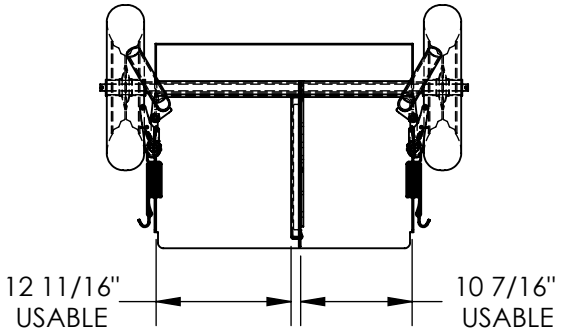

ALL GRAPHICS PROVIDED ARE FOR REFERENCE ONLY. IF CERTAIN DIMENSIONS ARE CRITICAL PLEASE VERIFY THOSE DIMENSIONS WITH YOUR SALESPERSON

DIMENSION TOLERANCE +/-1/4"

## STANDARD FEATURES

- MODEL NUMBER IS CYL-EH-FP-FF
- CAPACITY IS: 500 LBS
- OVERALL WIDTH IS 34 1/2"
- LEFT SIDE USABLE WIDTH IS 12 11/16"
- RIGHT SIDE USABLE WIDTH IS 10 7/16"
- OVERALL DEPTH IS 22 13/16"
- OVERALL HEIGHT IS 66 3/8"
- STRAPS TO SECURE TANKS
- DIVIDER WITH FIREPROOF MARINITE INSERT
- Ø16" FOAM FILLED WHEELS
- TOUGH BAKED IN POWDERCOATED YELLOW FINISH

## SPECIAL FEATURES

NONE

APPROVAL

I, THE UNDERSIGNED, AGREE THAT THE PRODUCT AS REPRESENTED SATISFIES DESIGN AND DIMENSION REQUIREMENTS. I ALSO ACKNOWLEDGE MY DUTY TO CONFIRM PRODUCT AND INSTALLATION COMPLIANCE WITH ALL APPLICABLE FEDERAL, STATE AND LOCAL REGULATIONS AND STANDARDS.  
**UNITS REQUIRING APPROVAL DRAWINGS OR MODIFIED ARE NON-RETURNABLE**  
[ ] As drawn [ ] As marked

Signed: \_\_\_\_\_ Date: \_\_\_\_\_

Printed Name: \_\_\_\_\_

LEAD TIME WILL START UPON RECEIPT OF SIGNED APPROVAL DRAWING

DISTRIBUTOR'S NAME:		P.O.#
VESTIL MANUFACTURING		X
DRAWN BY: TJM		W.O.#
DATE: 03/05/10		X
REFERENCE: X	SCALE: 1:18	SALES: X
QUOTED LEAD TIME: X	QUOTE #	FILE NAME:
	X	16-007-243